

PRELIMINARY DRAWING - FOR LAYOUT PURPOSES ONLY

REVISIONS			
REV	DESCRIPTION	DATE	BY

NOTE 1: Do not scale drawing. This drawing is for general truck configuration only. All items and dimensions shown are approximate and may vary with final production. The drawing may not provide illustration for all items in the specification. In all situations where the drawing may contradict the specifications, the specifications shall prevail. This drawing and all data herein are provided as confidential materials and shall not be reproduced without written consent of the manufacturer.

NOTE 2: Chassis frame height will change due to axle characteristics, loading and tire dimensions which will affect the overall height dimension shown. Any overall height restrictions should take this into consideration and allow approximately 2-3 inches of tolerance.

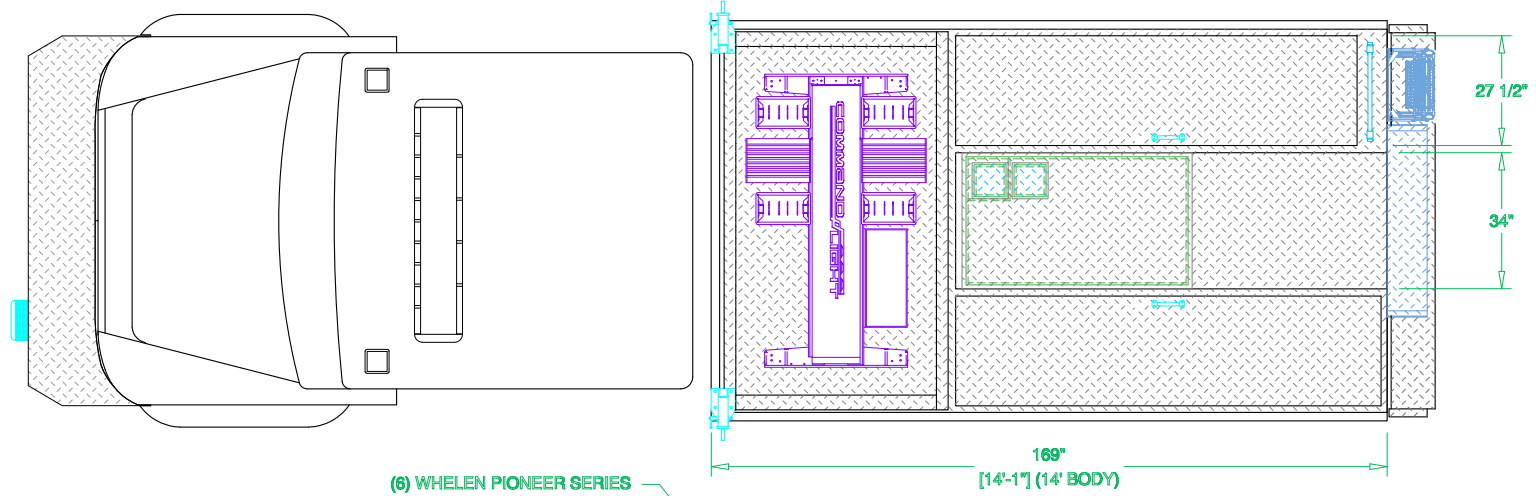

(6) WHELEN PIONEER SERIES LED SCENE LIGHTS (2 EACH SIDE, 2 REAR)

(6) WHELEN 900 SERIES RED LED WARNING LIGHTS (2 EACH SIDE, 2 REAR)

(6) WHELEN 600 SERIES RED LED WARNING LIGHTS (1 EACH SIDE, 2 FRONT, 2 REAR)

(6) WHELEN 500 SERIES RED LED WARNING LIGHTS (1 EACH SIDE)

WHELEN TRAFFIC ADVISOR TAM85

124 1/4" [10'-4"]

(2) WHELEN 600 SERIES TAIL LIGHTS IN INDIVIDUAL BEZELS

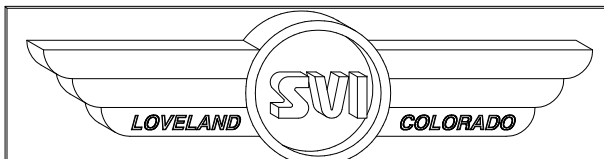
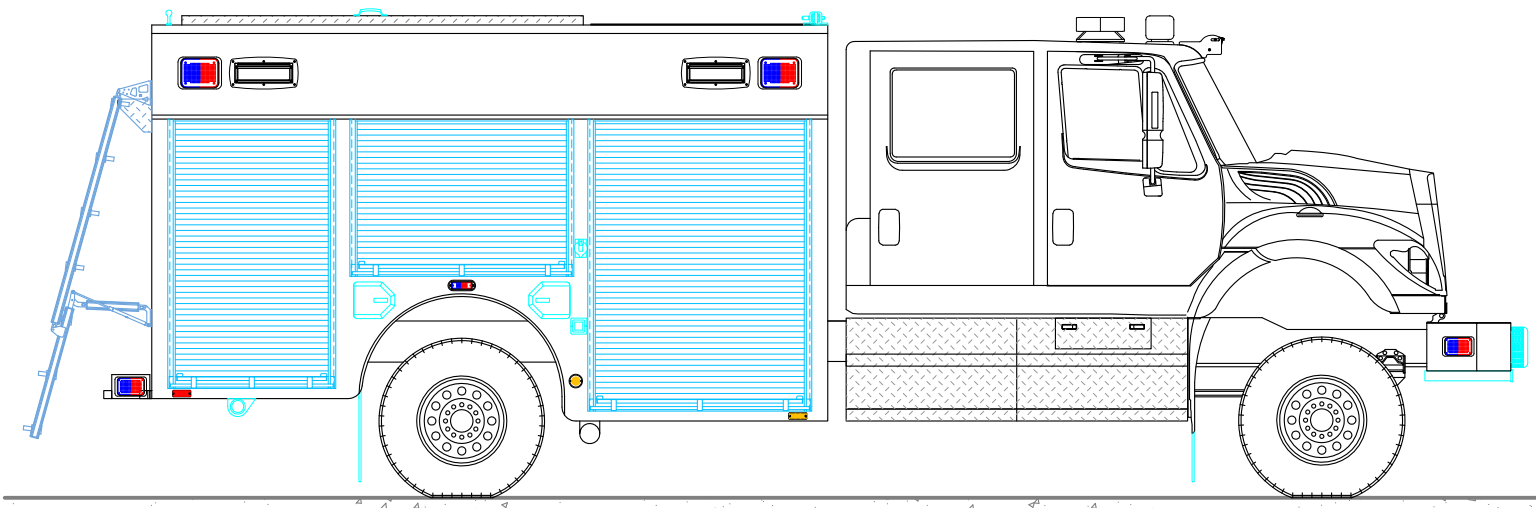
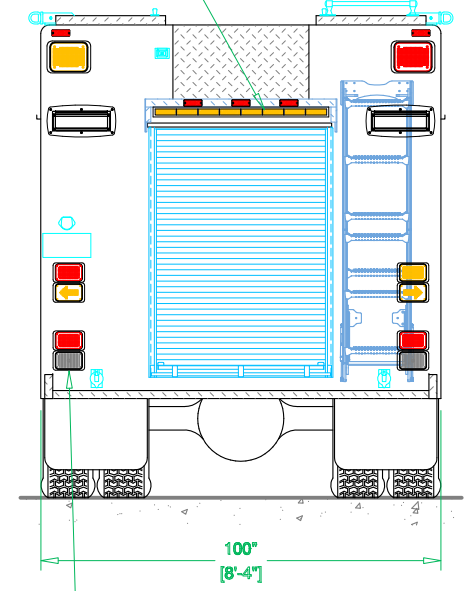
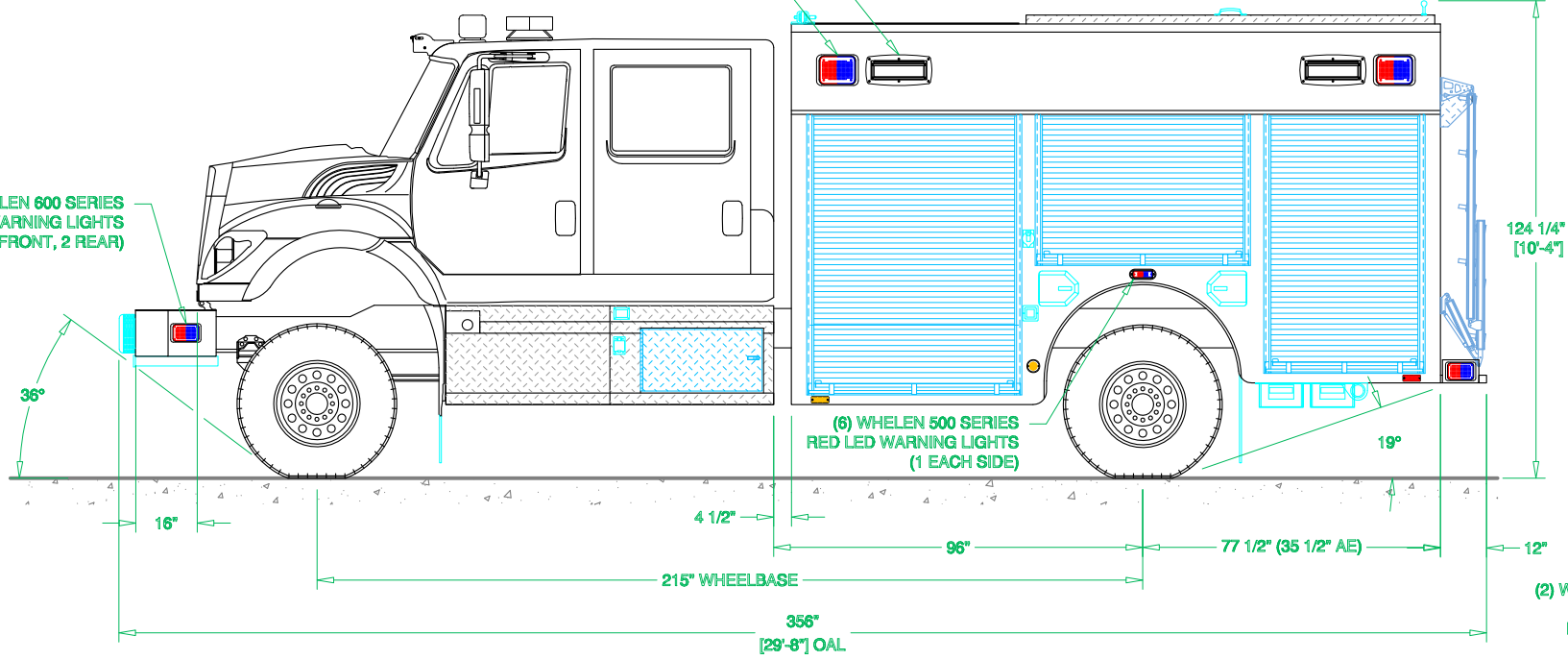
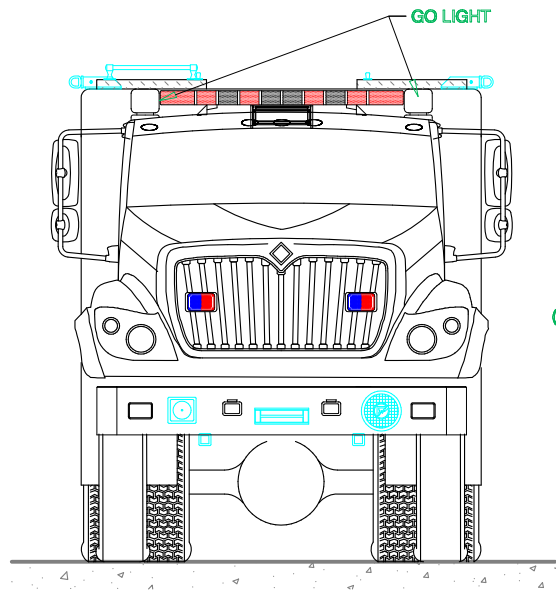

SVI FIRE & RESCUE TRUCKS
1511 E. 11th STREET, LOVELAND, CO 80537 PHONE 970-667-5146, FAX 970-667-3343

KREMMLING
FIRE DEPARTMENT

BODY SIZE: 14' BODY	UNIT TYPE: MEDIUM RESCUE
BODY MATERIAL: 3/16" ALUMINUM	TRUCK NO: SVI #000
CHASSIS TYPE: INTERNATIONAL	WHEELBASE: SEE DWG
7400	CAB TO AXLE: SEE DWG
4 x 4	OVERALL LENGTH (OAL): SEE DWG
FOUR DOOR	OVERALL WIDTH (OAW): SEE DWG
	OVERALL HEIGHT (OAH): SEE DWG

PRELIMINARY DRAWING - FOR LAYOUT PURPOSES ONLY

REVISIONS			
REV	DESCRIPTION	DATE	BY

NOTE 1: Do not scale drawing. This drawing is for general truck configuration only. All items and dimensions shown are approximate and may vary with final production. The drawing may not provide illustration for all items in the specification. In all situations where the drawing may contradict the specifications, the specifications shall prevail. This drawing and all data herein are provided as confidential materials and shall not be reproduced without written consent of the manufacturer.

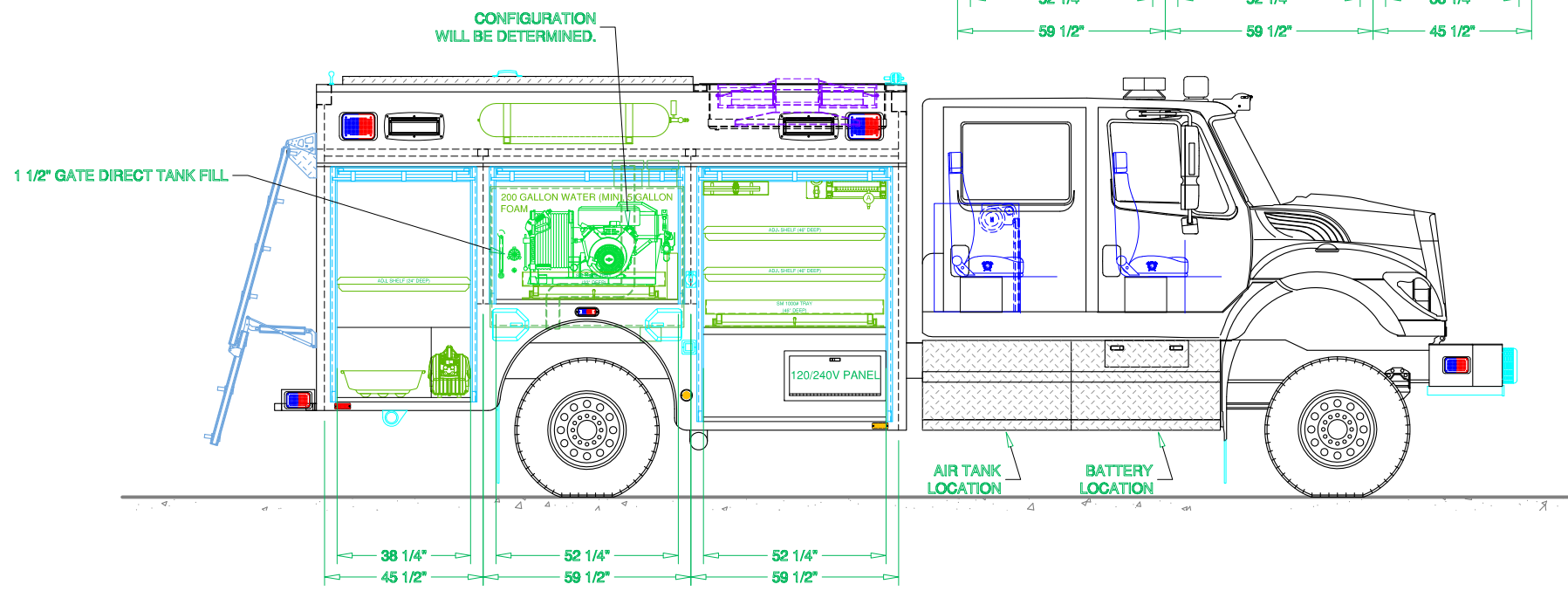
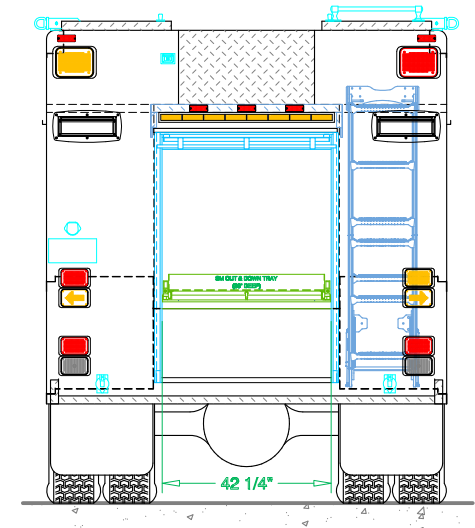
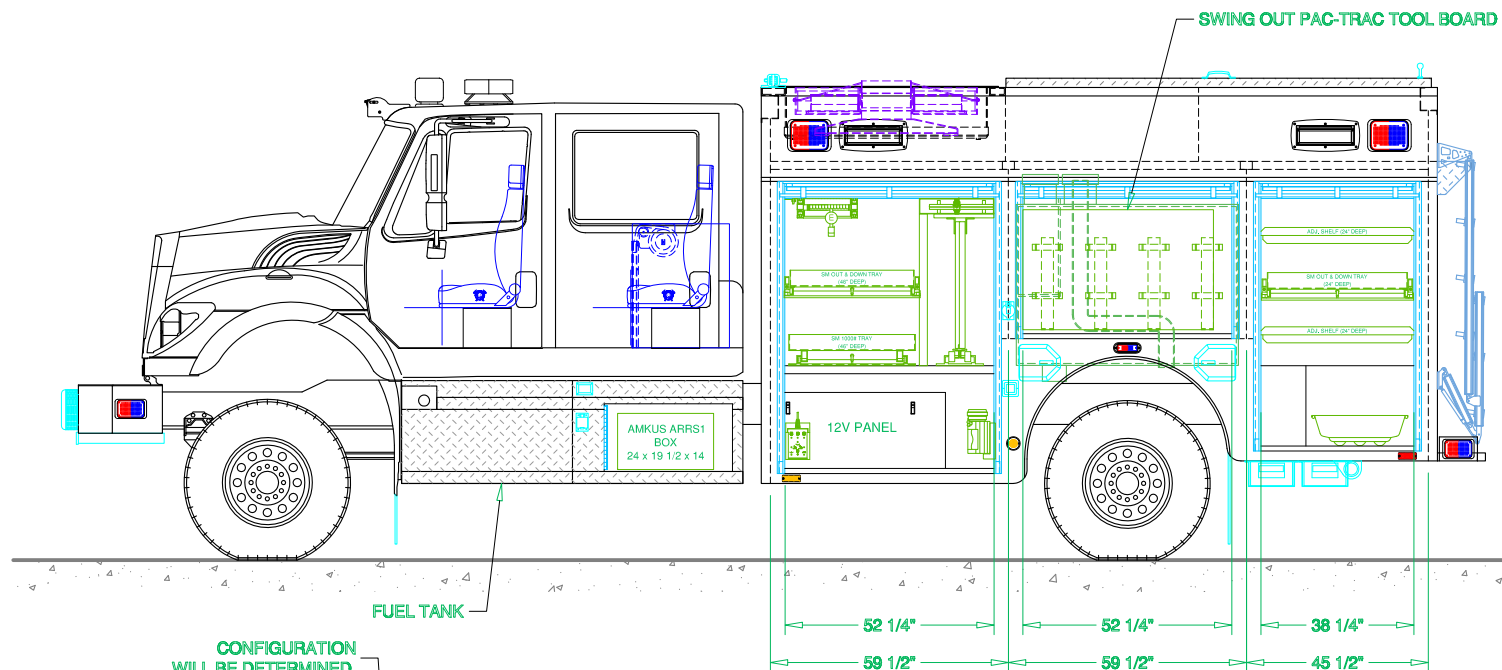
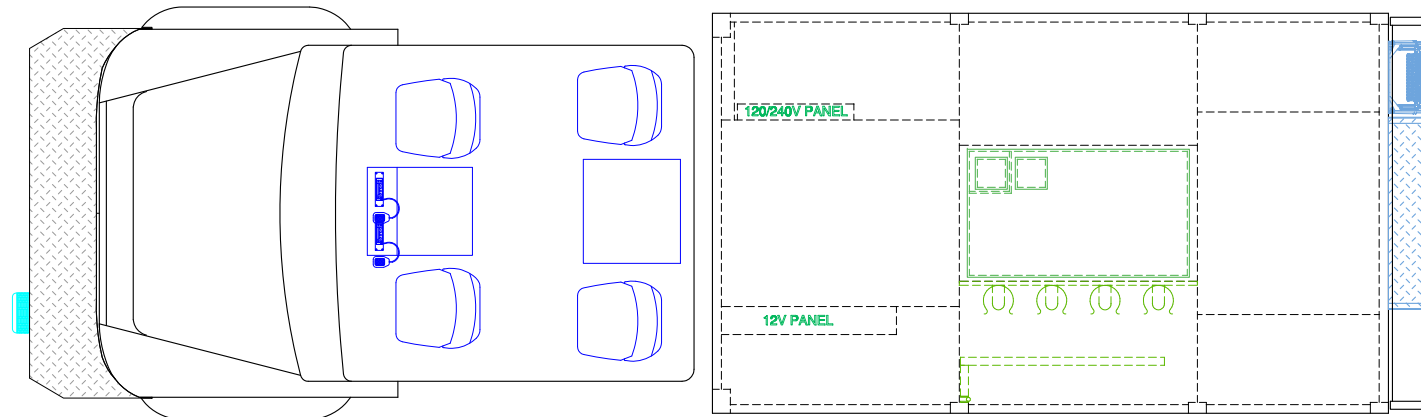



LOVELAND SVI COLORADO

SVI FIRE & RESCUE TRUCKS
1511 E. 11th STREET, LOVELAND, CO 80537 PHONE 970-667-5146, FAX 970-667-3343

**KREMMLING
FIRE DEPARTMENT**

DRAWN BY: JWG	DATE: JAN. 25, 2011	SCALE: 1/4" = 1'-0"
DRAWING NO: Kremmling_CO_mr_ProCon1		SHEET 2 OF 2